

LIGHTLIFT 17.75 *PERFORMANCE III* MK2

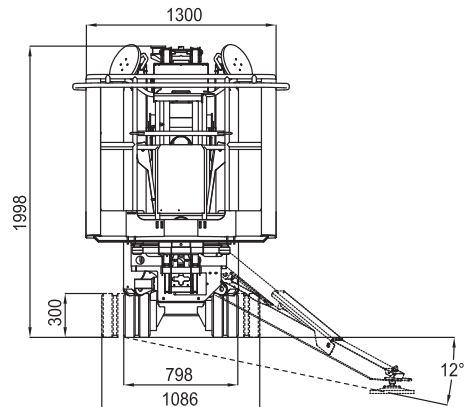

LIGHTLIFT 17.75 *PERFORMANCE III* MK2

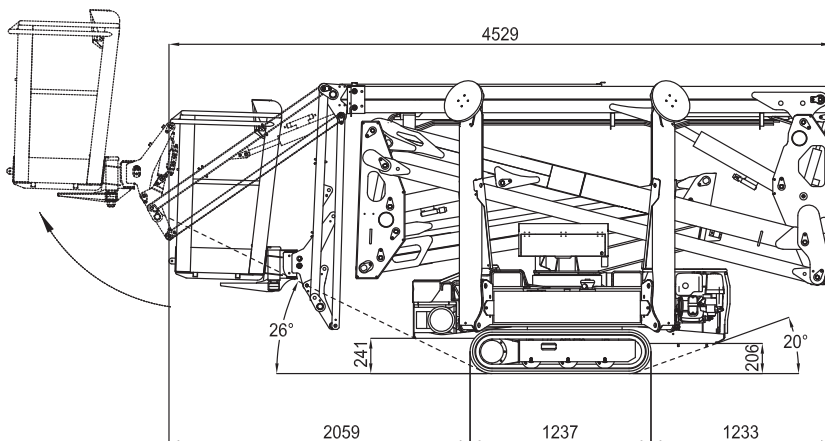
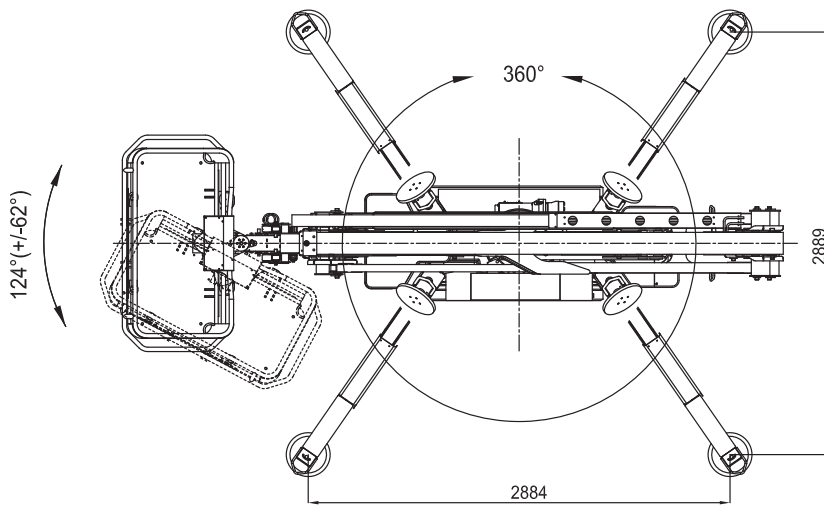
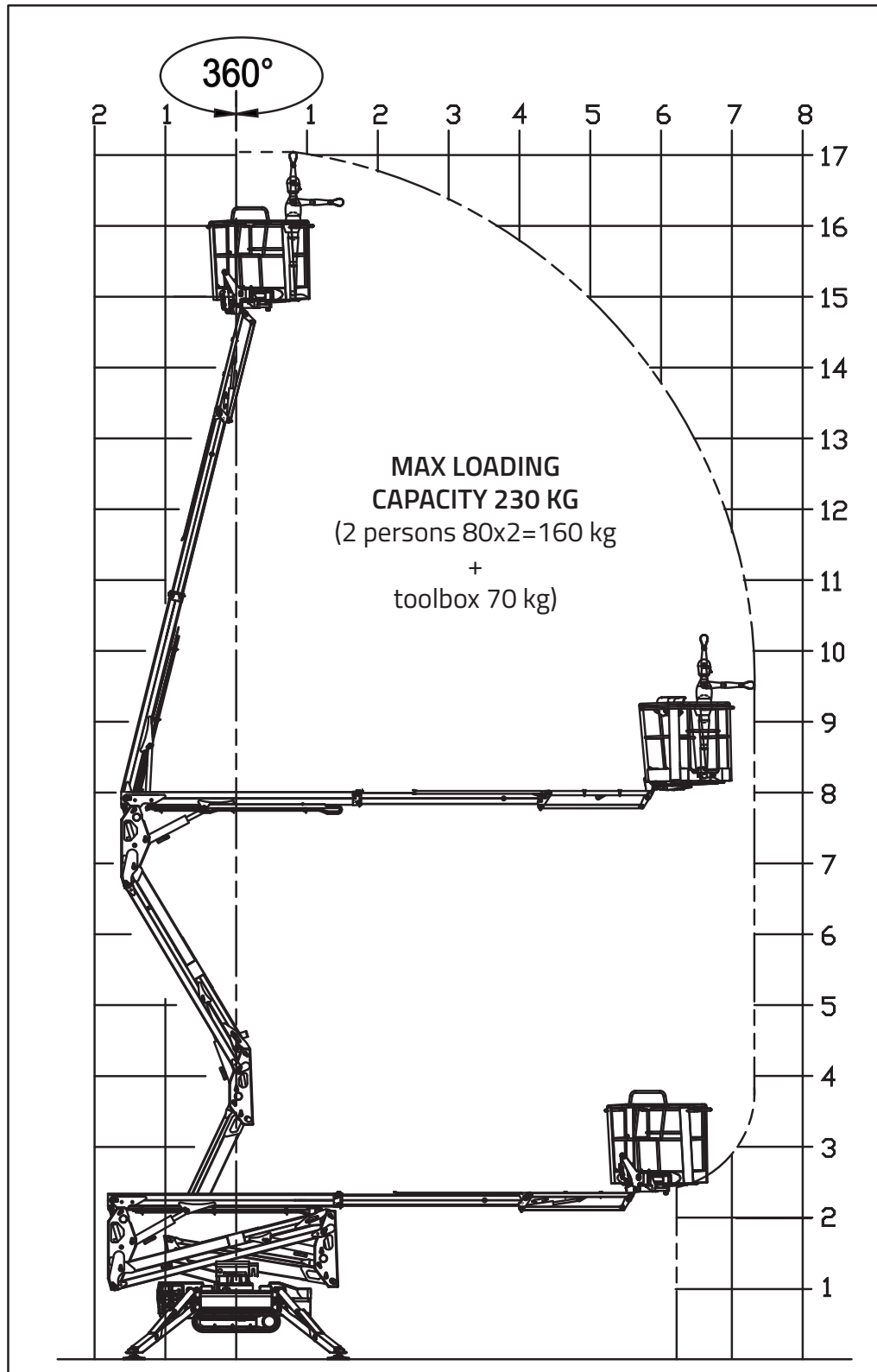

LIGHTLIFT 17.75 *PERFORMANCE III* MK2

PETROL ENGINE

Brand HONDA
 Type GX390
 Pistons no. and displacement single-cylinder 389 cm³
 Max. gross power 11,7HP - 8,7 kW @ 3600 rpm
 Electrical start 12 volt

DIESEL ENGINE

Brand HATZ
 Type 1B40 - HD Autorev
 Pistons no. and displacement single-cylinder 462 cm³
 Max. gross power 10 HP - 7,5 kW @ 3600 rpm
 Electrical start 12 volt

ELECTRIC MOTOR

Standard 230V / 50 Hz - 2,2 kW
 Optional 110V / 50 Hz - 2,2 kW

HYDRAULIC PUMPS

Pump diesel engine no. 2 gear pumps
 Pump electric motor no. 2 gear pumps

TRACKED UNDERCARRIAGE

Track tensioner grease-filled
 Rollers no. per side 3 + slide
 Widening system 798 / 1086 mm
 Max translation speed (petrol engine) with 2nd auto2speed 0,6 - 1,4 - 2,7 km/h
 Max translation speed (diesel engine) with 2nd auto2speed 0,7 - 1,8 - 3,6 km/h

WEIGHT MACHINE (petrol / diesel engine) 2230 kg
 MAX UPPER SLANT 16° / 28,7 %
 MAX WIND SPEED 12,5 m/s

LIGHTLIFT 17.75 PERFORMANCE III S MK2



ELECTRIC SYSTEM - LITHIUM ION

Electric system voltage	48V-12V
Lithium battery pack	4,8 KWh
Autonomy (continuous cycle)*	4-5 h
Onboard battery charger	220V 50Hz
Optional battery charger	110V 50Hz
Recharge time on flat batteries	4 h (indicative)
Recharge time to 80% on flat batteries	2 h (indicative)

HYDRAULIC PUMPS

Electric motor	no.2 gear pumps
----------------------	-----------------

TRACKED UNDERCARRIAGE

Track tensioner	grease-filled
Rollers no. per side	3 + slide
Widening system	798 / 1086 mm
Max translation speed with 2 nd auto2speed	0,4 - 0,8 - 1,6 km/h

WEIGHT MACHINE	2300 kg
MAX UPPER SLANT	16° / 28,7 %
MAX WIND SPEED	12,5 m/s

* (Autonomy measured with Hinowa H2 operating cycle)